

2K SPI Bus Serial EEPROM

Device Selection Table

Part Number	Vcc Range	Page Size	Temp. Ranges	Packages
25AA020A	1.8-5.5V	16 Bytes	I	P, MS, SN, ST, MC, OT
25LC020A	2.5-5.5V	16 Bytes	I, E	P, MS, SN, ST, MC, OT

Features:

- 10 MHz max. Clock Frequency
- Low-Power CMOS Technology:
 - Max. Write Current: 5 mA at 5.5V, 10 MHz
 - Read Current: 5 mA at 5.5V, 10 MHz
 - Standby Current: 5 μ A at 5.5V
- 256 x 8-bit Organization
- Write Page mode (up to 16 bytes)
- Sequential Read
- Self-Timed Erase and Write Cycles (5 ms max.)
- Block Write Protection:
 - Protect none, 1/4, 1/2 or all of array
- Built-in Write Protection:
 - Power-on/off data protection circuitry
 - Write enable latch
 - Write-protect pin
- High Reliability:
 - Endurance: 1,000,000 Erase/Write cycles
 - Data retention: >200 years
 - ESD protection: >4000V
- Temperature Ranges Supported:
 - Industrial (I): -40°C to +85°C
 - Automotive (E): -40°C to +125°C
- Pb-Free and RoHS Compliant

Description:

The Microchip Technology Inc. 25XX020A* is a 2 Kbit Serial Electrically Erasable Programmable Read-Only Memory (EEPROM). The memory is accessed via a simple Serial Peripheral Interface (SPI) compatible serial bus. The bus signals required are a clock input (SCK) plus separate data in (SI) and data out (SO) lines. Access to the device is controlled through a Chip Select (CS) input.

Communication to the device can be paused via the hold pin (HOLD). While the device is paused, transitions on its inputs will be ignored, with the exception of Chip Select, allowing the host to service higher priority interrupts.

The 25XX020A is available in standard packages including 8-lead PDIP and SOIC, and advanced packages including 8-lead MSOP, 8-lead TSSOP and rotated TSSOP, 8-lead 2x3 DFN, and 6-lead SOT-23.

Package Types (not to scale)

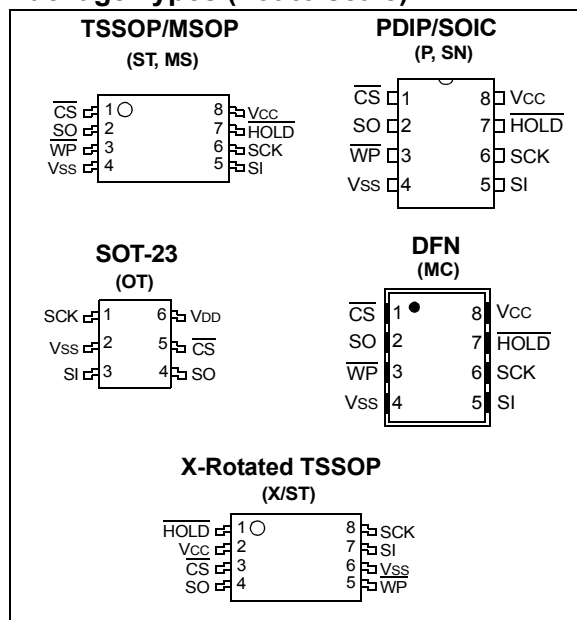

Pin Function Table

Name	Function
CS	Chip Select Input
SO	Serial Data Output
WP	Write-Protect
Vss	Ground
SI	Serial Data Input
SCK	Serial Clock Input
HOLD	Hold Input
Vcc	Supply Voltage

*25XX020A is used in this document as a generic part number for the 25AA020A and the 25LC020A.

25AA020A/25LC020A

1.0 ELECTRICAL CHARACTERISTICS

Absolute Maximum Ratings^(†)

V _{CC}	6.5V
All inputs and outputs w.r.t. V _{SS}	-0.6V to V _{CC} +1.0V
Storage temperature	-65°C to 150°C
Ambient temperature under bias	-40°C to 125°C
ESD protection on all pins	4 kV

† NOTICE: Stresses above those listed under “Absolute Maximum Ratings” may cause permanent damage to the device. This is a stress rating only and functional operation of the device at those or any other conditions above those indicated in the operational listings of this specification is not implied. Exposure to maximum rating conditions for an extended period of time may affect device reliability.

TABLE 1-1: DC CHARACTERISTICS

DC CHARACTERISTICS			Industrial (I): TA = -40°C to +85°C		V _{CC} = 1.8V to 5.5V	
			Automotive (E): TA = -40°C to +125°C		V _{CC} = 2.5V to 5.5V	
Param. No.	Sym.	Characteristic	Min.	Max.	Units	Test Conditions
D001	V _{IH1}	High-level Input Voltage	0.7 V _{CC}	V _{CC} +1	V	
D002	V _{IL1}	Low-level Input Voltage	-0.3	0.3 V _{CC}	V	V _{CC} ≥ 2.7V (Note 1)
D003	V _{IL2}		-0.3	0.2 V _{CC}	V	V _{CC} < 2.7V (Note 1)
D004	V _{OL}	Low-level Output Voltage	—	0.4	V	I _{OL} = 2.1 mA
D005	V _{OL}		—	0.2	V	I _{OL} = 1.0 mA, V _{CC} < 2.5V
D006	V _{OH}	High-level Output Voltage	V _{CC} -0.5	—	V	I _{OH} = -400 μA
D007	I _{LI}	Input Leakage Current	—	±1	μA	$\overline{CS} = V_{CC}$, V _{IN} = V _{SS} TO V _{CC}
D008	I _{LO}	Output Leakage Current	—	±1	μA	$\overline{CS} = V_{CC}$, V _{OUT} = V _{SS} TO V _{CC}
D009	C _{INT}	Internal Capacitance (all inputs and outputs)	—	7	pF	TA = 25°C, CLK = 1.0 MHz, V _{CC} = 5.0V (Note 1)
D010	I _{CC} Read	Operating Current	—	5	mA	V _{CC} = 5.5V; F _{CLK} = 10.0 MHz; SO = Open
			—	2.5	mA	V _{CC} = 2.5V; F _{CLK} = 5.0 MHz; SO = Open
D011	I _{CC} Write		—	5	mA	V _{CC} = 5.5V
			—	3	mA	V _{CC} = 2.5V
D012	I _{CCS}	Standby Current	—	5	μA	$\overline{CS} = V_{CC} = 5.5V$, Inputs tied to V _{CC} or V _{SS} , TA = +125°C
			—	1	μA	$\overline{CS} = V_{CC} = 2.5V$, Inputs tied to V _{CC} or V _{SS} , TA = +85°C

Note: This parameter is periodically sampled and not 100% tested.

TABLE 1-2: AC CHARACTERISTICS

AC CHARACTERISTICS			Industrial (I):		Automotive (E):		$T_A = -40^{\circ}\text{C to } +85^{\circ}\text{C}$ $V_{CC} = 1.8\text{V to } 5.5\text{V}$	
Param. No.	Sym.	Characteristic	Min.	Max.	Units	Test Conditions		
1	FCLK	Clock Frequency	—	10	MHz	$4.5\text{V} \leq V_{CC} < 5.5\text{V}$		
			—	5	MHz	$2.5\text{V} \leq V_{CC} < 4.5\text{V}$		
			—	3	MHz	$1.8\text{V} \leq V_{CC} < 2.5\text{V}$		
2	T _{CSS}	$\overline{\text{CS}}$ Setup Time	50	—	ns	$4.5\text{V} \leq V_{CC} < 5.5\text{V}$		
			100	—	ns	$2.5\text{V} \leq V_{CC} < 4.5\text{V}$		
			150	—	ns	$1.8\text{V} \leq V_{CC} < 2.5\text{V}$		
3	T _{CSH}	$\overline{\text{CS}}$ Hold Time	100	—	ns	$4.5\text{V} \leq V_{CC} < 5.5\text{V}$		
			200	—	ns	$2.5\text{V} \leq V_{CC} < 4.5\text{V}$		
			250	—	ns	$1.8\text{V} \leq V_{CC} < 2.5\text{V}$		
4	T _{CSD}	$\overline{\text{CS}}$ Disable Time	50	—	ns	—		
5	T _{SU}	Data Setup Time	10	—	ns	$4.5\text{V} \leq V_{CC} < 5.5\text{V}$		
			20	—	ns	$2.5\text{V} \leq V_{CC} < 4.5\text{V}$		
			30	—	ns	$1.8\text{V} \leq V_{CC} < 2.5\text{V}$		
6	T _{HD}	Data Hold Time	20	—	ns	$4.5\text{V} \leq V_{CC} < 5.5\text{V}$		
			40	—	ns	$2.5\text{V} \leq V_{CC} < 4.5\text{V}$		
			50	—	ns	$1.8\text{V} \leq V_{CC} < 2.5\text{V}$		
7	T _R	CLK Rise Time	—	2	μs	(Note 1)		
8	T _F	CLK Fall Time	—	2	μs	(Note 1)		
9	T _{HI}	Clock High Time	0.05	1000	μs	$4.5\text{V} \leq V_{CC} < 5.5\text{V}$		
			0.1	1000	μs	$2.5\text{V} \leq V_{CC} < 4.5\text{V}$		
			0.15	1000	μs	$1.8\text{V} \leq V_{CC} < 2.5\text{V}$		
10	T _{LO}	Clock Low Time	0.05	1000	μs	$4.5\text{V} \leq V_{CC} < 5.5\text{V}$		
			0.1	1000	μs	$2.5\text{V} \leq V_{CC} < 4.5\text{V}$		
			0.15	1000	μs	$1.8\text{V} \leq V_{CC} < 2.5\text{V}$		
11	T _{CLD}	Clock Delay Time	50	—	ns	—		
12	T _{CLE}	Clock Enable Time	50	—	ns	—		
13	T _V	Output Valid from Clock Low	—	50	ns	$4.5\text{V} \leq V_{CC} < 5.5\text{V}$		
			—	100	ns	$2.5\text{V} \leq V_{CC} < 4.5\text{V}$		
			—	160	ns	$1.8\text{V} \leq V_{CC} < 2.5\text{V}$		
14	T _{HO}	Output Hold Time	0	—	ns	(Note 1)		
15	T _{DIS}	Output Disable Time	—	40	ns	$4.5\text{V} \leq V_{CC} < 5.5\text{V}$ (Note 1)		
			—	80	ns	$2.5\text{V} \leq V_{CC} < 4.5\text{V}$ (Note 1)		
			—	160	ns	$1.8\text{V} \leq V_{CC} < 2.5\text{V}$ (Note 1)		
16	T _{HS}	$\overline{\text{HOLD}}$ Setup Time	20	—	ns	$4.5\text{V} \leq V_{CC} < 5.5\text{V}$		
			40	—	ns	$2.5\text{V} \leq V_{CC} < 4.5\text{V}$		
			80	—	ns	$1.8\text{V} \leq V_{CC} < 2.5\text{V}$		

Note 1: This parameter is periodically sampled and not 100% tested.

2: This parameter is not tested but ensured by characterization. For endurance estimates in a specific application, please consult the Total Endurance™ Model which can be obtained from Microchip's web site

3: T_{wc} begins on the rising edge of $\overline{\text{CS}}$ after a valid write sequence and ends when the internal write cycle is complete.

25AA020A/25LC020A

TABLE 1-2: AC CHARACTERISTICS (CONTINUED)

AC CHARACTERISTICS			Industrial (I):		Automotive (E):		TA = -40°C to +85°C		VCC = 1.8V to 5.5V		
			TA = -40°C to +125°C		VCC = 2.5V to 5.5V						
Param. No.	Sym.	Characteristic	Min.	Max.	Units	Test Conditions					
17	THH	$\overline{\text{HOLD}}$ Hold Time	20	—	ns	4.5V ≤ VCC < 5.5V					
			40	—	ns	2.5V ≤ VCC < 4.5V					
			80	—	ns	1.8V ≤ VCC < 2.5V					
18	THZ	$\overline{\text{HOLD}}$ Low to Output High-Z	30	—	ns	4.5V ≤ VCC < 5.5V (Note 1)					
			60	—	ns	2.5V ≤ VCC < 4.5V (Note 1)					
			160	—	ns	1.8V ≤ VCC < 2.5V (Note 1)					
19	THV	$\overline{\text{HOLD}}$ High to Output Valid	30	—	ns	4.5V ≤ VCC < 5.5V					
			60	—	ns	2.5V ≤ VCC < 4.5V					
			160	—	ns	1.8V ≤ VCC < 2.5V					
20	Twc	Internal Write Cycle Time (byte or page)	—	5	ms	(Note 3)					
21	—	Endurance	1M	—	E/W Cycles	(NOTE 2)					

Note 1: This parameter is periodically sampled and not 100% tested.

2: This parameter is not tested but ensured by characterization. For endurance estimates in a specific application, please consult the Total Endurance™ Model which can be obtained from Microchip's web site at www.Microchip.com.

3: Twc begins on the rising edge of $\overline{\text{CS}}$ after a valid write sequence and ends when the internal write cycle is complete.

TABLE 1-3: AC TEST CONDITIONS

AC Waveform:	
VLO = 0.2V	—
VHI = VCC - 0.2V	(Note 1)
VHI = 4.0V	(Note 2)
CL = 100 pF	—
Timing Measurement Reference Level	
Input	0.5 VCC
Output	0.5 VCC

Note 1: For VCC ≤ 4.0V

2: For VCC > 4.0V

25AA020A/25LC020A

8-Lead Plastic Small Outline (SN) – Narrow, 3.90 mm Body [SOIC]

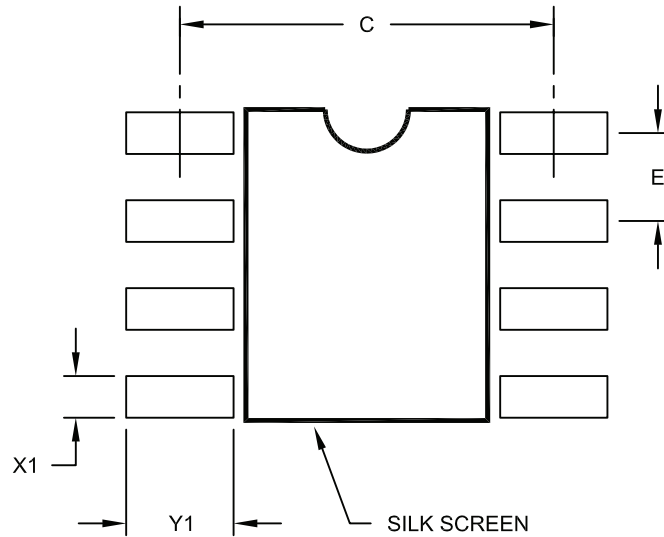

RECOMMENDED LAND PATTERN

Dimension Limits	Units	MILLIMETERS		
		MIN	NOM	MAX
Contact Pitch	E	1.27 BSC		
Contact Pad Spacing	C		5.40	
Contact Pad Width (X8)	X1			0.60
Contact Pad Length (X8)	Y1			1.55

Notes:

1. Dimensioning and tolerancing per ASME Y14.5M

BSC: Basic Dimension. Theoretically exact value shown without tolerances.

Microchip Technology Drawing No. C04-2057A

25AA020A/25LC020A

PRODUCT IDENTIFICATION SYSTEM

To order or obtain information, e.g., on pricing or delivery, refer to the factory or the listed sales office.

<u>PART NO.</u>		<u>X</u>	-	<u>X</u>	<u>/XX</u>
Device	Tape & Reel	Temperature		Package	
Device:	25AA020A	2k-Bit, 1.8V, 16 Byte Page, SPI Serial EEPROM			
	25LC020A	2k-Bit, 2.5V, 16 Byte Page, SPI Serial EEPROM			
Tape & Reel:	Blank	= Standard packaging			
	T	= Tape & Reel			
Temperature Range:	I	= -40°C to+85°C			
	E	= -40°C to+125°C			
Package:	MS	= Plastic MSOP (Micro Small Outline), 8-lead			
	P	= Plastic DIP (300 mil body), 8-lead			
	SN	= Plastic SOIC (3.90 mm body), 8-lead			
	ST	= TSSOP, 8-lead			
	MC	= 2x3 DFN, 8-lead			
	OT	= SOT-23, 6-lead (Tape and Reel only)			

Examples:

- 25AA020A-I/MS = 2k-bit, 16-byte page, 1.8V Serial EEPROM, Industrial temp., MSOP package
- 25AA020AT-I/SN = 2k-bit, 16-byte page, 1.8V Serial EEPROM, Industrial temp., Tape & Reel, SOIC package
- 25LC020AT-I/SN = 2k-bit, 16-byte page, 2.5V Serial EEPROM, Industrial temp., Tape & Reel, SOIC package
- 25LC020AT-I/ST = 2k-bit, 16-byte page, 2.5V Serial EEPROM, Industrial temp., Tape & Reel, TSSOP package
- 25LC020AT-E/SN = 2k-bit, 16-byte page, 2.5V serial EEPROM, Extended temp., Tape & Reel, SOIC Package